

# Review 06

EN

## The Commission's 2022 annual management and performance report for the EU budget



EUROPEAN  
COURT  
OF AUDITORS

2023

# Contents

	Paragraph
<b>Executive summary</b>	I-VI
<b>Introduction</b>	01-05
<b>Scope and approach</b>	06-10
<b>Preparation and adoption of the AMPR</b>	11-20
<b>Performance-related messages in Volume I of the 2022 AMPR</b>	21-37
<b>Reporting on performance</b>	21-24
<b>Consistency of the AMPR with our reports</b>	25-36
<b>Accuracy of the quantitative assertions related to performance in Volume I of the 2022 AMPR</b>	37
<b>Concluding remarks</b>	38-44
<b>Annexes</b>	
<b>Annex I – Roles of different participants in producing the Commission’s main performance reporting documents</b>	
<b>Annex II – Programme performance statements</b>	
<b>Abbreviations</b>	
<b>Glossary</b>	
<b>ECA team</b>	

## Executive summary

I Every year, in its annual management and performance report (AMPR), the Commission provides an account of the management of the EU budget and the performance of EU programmes and policies. With its adoption, the College of Commissioners takes overall political responsibility for the management of the EU budget. This report is a key document in the annual discharge procedure where the European Parliament, following a recommendation from the Council, holds the Commission to account for the implementation of the EU budget.

II The Commission is required to provide us with the AMPR of a specific year by the end of June of the following year. As there is limited time for us to review the report before the annual discharge procedure, we looked at how the Commission prepared the 2022 AMPR and reported on performance-related issues, focusing on Volume I. In addition, our [annual report for 2022](#) included a chapter on performance with key performance messages from the special reports we published in 2022.

III As this is a review rather than an audit report, we have based our work on publicly available information and our previous audit work. We also obtained information and explanations from the Commission. The review takes into consideration stakeholders' interests and more specifically the European Parliament's report on discharge of May 2023.

IV Overall, we noted from the review that Volume I of the 2022 AMPR followed the Commission's corporate management board strategic guidance when it presented the facts and achievements in relation to budgetary management for 2022. We have also previously reported that the Commission had good, well-defined procedures for preparing the AMPR but there was still scope for improvement concerning data quality.

V An observation we made in our [special report 09/2022](#), and in our [2021 annual report on performance](#) relating to the overstatement of the Commission's calculation of the contribution of the common agricultural policy to climate expenditure was also relevant for the 2022 AMPR. An updated tracking methodology for the new common agricultural policy will apply from 2023. Concerning the content of our [2022 annual report](#), the AMPR reflects the fact that the Commission does not share the same conclusions as the ECA on specific expenditure areas, with the ECA reporting more errors affecting the regularity of payments.

**VI** Our review of the main financial assertions presented in Volume I of the AMPR did not identify other inconsistencies.

# Introduction

**01** The annual management and performance report (AMPR) is the Commission's high-level annual performance report on the EU budget. It is a key input for the annual discharge procedure through which the European Parliament, following a recommendation from the Council, scrutinises the implementation of the EU budget. The AMPR is part of the Commission's integrated financial and accountability reporting that also includes the consolidated annual accounts of the EU, a long-term forecast of future inflows and outflows of the EU budget (2024-2028), the report to the discharge authority on internal audits carried out in the previous year, and the report on the follow-up to the discharge for the previous year. The legal deadline for the Commission to make available to the European Parliament, the Council and the ECA the AMPR for year n is the end of June of year n+1.

**02** The Commission first prepared an AMPR for the year 2015, which combined two former reports: the evaluation report<sup>1</sup> on the Union's finances based on the results achieved, and the synthesis report<sup>2</sup> which summarised the annual activity reports (AARs) of the Commission's delegated authorising officers. By combining two previously separate reports, the Commission aimed to produce a single document for the discharge authority covering both the management of the EU budget and the Commission's evaluation of the results obtained. The Financial Regulation (FR)<sup>3</sup> requires the Commission to prepare the AMPR, with specific reporting requirements, and an evaluation of the Union's finances based on the results achieved.

**03** Since 2020, the AMPR has been organised in three volumes:

- Volume I lays out the key facts and achievements in relation to budgetary management and protection the EU budget;
- Volume II presents a detailed picture of how the EU budget is implemented, providing an overview of how EU spending programmes have contributed to President von der Leyen's political priorities (Annex 1), the internal control and

---

<sup>1</sup> Article 318 of the [Treaty on the Functioning of the European Union](#).

<sup>2</sup> Article 66(9) of the [former Financial Regulation](#).

<sup>3</sup> Articles 247(1)(b) and 247(1)(e) of the [Financial Regulation](#).

financial management (Annex 2), and performance and compliance aspects of the Recovery and Resilience Facility (RRF) (Annex 3);

- o Volume III contains eight technical annexes supporting the report, including amongst others detailed, standardised reporting on the performance of spending programmes (Annex 4). Since the 2022 AMPR, these are called ‘programme performance statements’ (PPSs) (see [Annex II](#)).

**04** *Figure 1* summarises the presentation of the AMPR in the years from 2015 to 2022.

**Figure 1 – Development of AMPR structure**

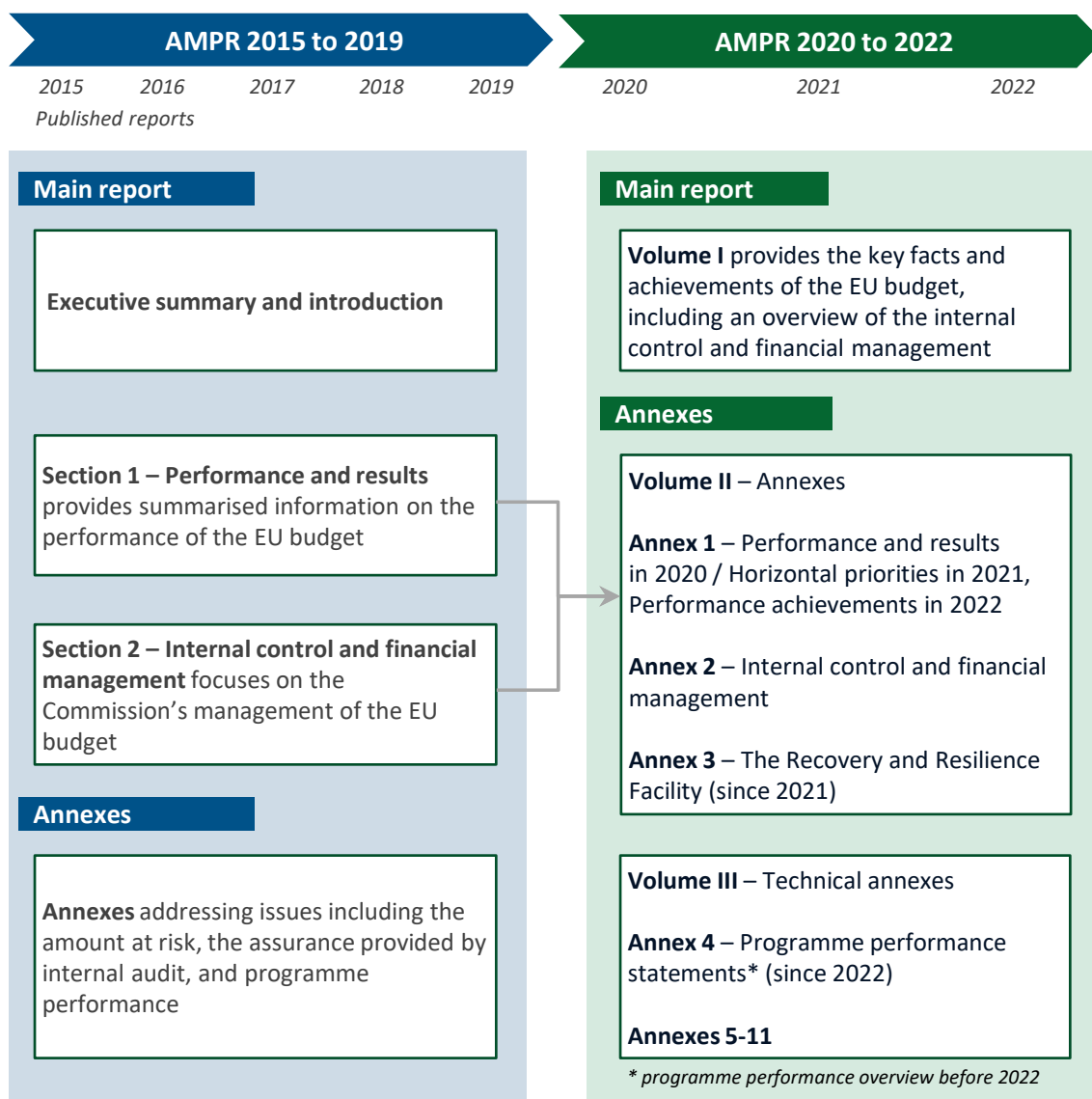

**05** Volume I of the 2022 AMPR ends with a management conclusion and a statement by the College of Commissioners that it takes overall political responsibility for the management of the budget. This volume reports on:

- the EU funded response to the crisis caused by Russia's war of aggression against Ukraine, including political, humanitarian and financial support for Ukraine; and support for member states to face the consequences of the war;
- the EU funds used to promote recovery after the COVID-19 pandemic, on the green and digital priorities and on RRF deployment;
- the tools to ensure accountability, transparency and sound financial management of the EU budget, including RRF controls;
- the new conditionality regime for protecting the EU budget.

## Scope and approach

**06** Every year, we cover aspects concerning the performance of the EU budget in our annual report. The AMPR is made available to us in June of the following year (see paragraph **01**), by which time we need to have completed our audit work for the annual report of the year in question. This somewhat limits our coverage of the AMPR in our annual report for the same year. For 2019, 2020 and 2021, we split our annual report into two parts. The first part covered the reliability of the EU accounts and the legality and regularity of underlying transactions. The second covered performance and it was published shortly after the first part.

**07** For 2022, we returned to our pre-2019 practice and published our annual report as one volume, with a chapter on performance, which contained the key performance messages from the special reports we published in 2022. In addition, we are publishing this separate review.

**08** This review covers the following aspects related to Volume I of the Commission's 2022 AMPR:

- how the Commission prepared the AMPR, including related controls;
- how the Commission reports on performance-related issues, including the consistency of the AMPR with relevant reports from the ECA, and the accuracy of quantified assertions.

**09** As this is a review rather than an audit report, we have based our work on publicly available information, such as Commission documents and our own previous work. We also obtained relevant explanations from the Commission's (Directorate-General for Budget (DG BUDG) and Secretariat-General (SEC-GEN)) services, and we covered control activities carried out by these central services to prepare the AMPR.

**10** This review takes into consideration stakeholders' interests and more specifically the European Parliament's [report on discharge](#)<sup>4</sup> from May 2023. This report called for the ECA to take account of the AMPR in its annual reporting or through a separate document, if necessary, in order to account for the annual discharge exercise. The fact that the Commission is required to make the AMPR for the year n available by the end of June n+1 combined with the interest of our stakeholders to receive our work on the AMPR in time for the discharge of year n, means that we had limited time to review the AMPR. Consequently, we focused on Volume I.

---

<sup>4</sup> European Parliament resolution of 10 May 2023 with observations forming an integral part of the decisions on discharge in respect of the implementation of the general budget of the European Union for the financial year 2021, Section III – Commission and executive agencies.

## Preparation and adoption of the AMPR

**11** The Commission's corporate management board<sup>5</sup> provided strategic guidance for the structure and content of the 2022 AMPR. The guidance included that Volume I of the AMPR should be concise and political in style, contain a high-level overview of the performance of the EU budget in 2022 and provide a summary of the achievements of budgetary management. Work on the AMPR was led by two of the Commission's 'central services': namely the SEC-GEN and DG BUDG, which followed the strategic guidance of the corporate management board.

**12** This year's strategic guidance set as main priorities to be included in the 2022 AMPR the EU's response to Russia's war of aggression against Ukraine, to the COVID-19 pandemic, and to the main challenges ahead (e.g. climate change and digitalisation), and updates on the RRF's implementation.

**13** The AMPR was prepared based on contributions by the Commission's services responsible for the various spending programmes and for producing the AARs and PPSs. DG BUDG issued detailed instructions to the other DGs to guide them when preparing their budget submission documents including the PPS, and the AARs. Stand-alone evaluations with significant findings were also considered when drafting the AMPR's main messages. [Figure 2](#) presents a simplified process of how the AMPR was compiled and adopted.

---

<sup>5</sup> Heading 1.4 'The corporate management board' in *Communication to the Commission: Governance in the European Commission*, Brussels, 24.6.2020, C(2020) 4240 final.

**Figure 2 – The AMPR process: from preparation to publication**

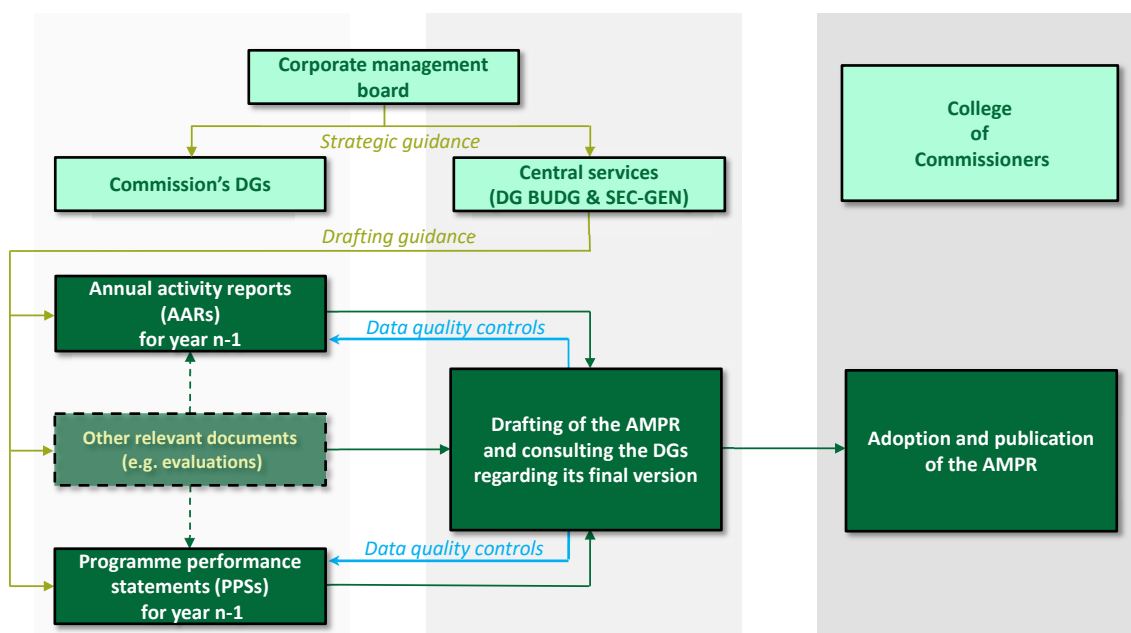

Source: ECA.

**14** Once DG BUDG and the SEC-GEN produced the first AMPR draft, the inter-service consultations began and Commission directorates-general (DGs) were invited to provide their feedback. After these consultations, the draft was reviewed again by DG BUDG and the SEC-GEN, and then by the Commissioners' private offices, before being sent to the College of Commissioners for adoption. *Annex I* presents the roles of the different parties involved in preparing the AMPR.

**15** The technical annexes contained in Volume III of the AMPR included the PPSs, showing the progress made in achieving each spending programme's objectives, using indicators defined in the relevant programme legislation. For 2022, DG BUDG upgraded its system for collecting indicator data to an SAP based tool, with a user-friendly interface for input at DG level. According to the Commission, the data input process integrated checks on data quality. These verifications check for completeness, formatting (for example as a date or number) and reasonableness (numbers need to be within reasonable ranges). DG BUDG reviewed the data once again after the PPSs were prepared, based on their knowledge of the programmes.

**16** The AARs are management reports sent from the head of each Commission DG to the College of Commissioners. These reports account for the performance of the DG concerned, rather than that of the programmes managed (as is the case for the PPSs). The AARs provide financial and management information, including a declaration of assurance signed by each director-general, stating that the control procedures in place

provide the necessary guarantees that spending has been legal and regular, and that resources have been used for their intended purpose and in accordance with the principle of sound financial management. The central services reviewed the draft AARs and provided feedback to the DGs responsible.

**17** We have previously reported that the Commission had good, well-defined procedures for preparing its AMPR, but that it did not fully control or guarantee the reliability of performance information<sup>6</sup>.

**18** In our [2019 annual report on performance](#), we recommended that the Commission further improve the reliability of the performance information presented in programme statements and in the AMPR. The Commission accepted this recommendation, but stated that it was not in a position to fully control or guarantee the reliability of performance information provided by others.

**19** We reported on the follow-up of this recommendation in our [2022 annual report](#), and considered that this recommendation had been implemented in some respects. This was because the Commission's central service guidelines should include additional details regarding checks to be performed by the DGs on the underlying data, and the results of these checks should be reported in their AARs. The Commission replied that it had established an action plan to address the Internal Audit Service's recommendations that will ensure enhancements both to the control framework and to the reporting as of the next reporting cycle.

**20** Furthermore, concerning data reliability, 10 out of our 28 special reports published in 2022 contained recommendations on data collection, monitoring and reporting of the key performance indicators<sup>7</sup>. The Commission fully or partially accepted all but one of these recommendations.

---

<sup>6</sup> [Report of the European Court of Auditors on the performance of the EU budget – Status at the end of 2019](#), headings above paragraphs 1.8 and 1.13.

<sup>7</sup> Special reports [01/2022](#), [15/2022](#) and [27/2022](#).

# Performance-related messages in Volume I of the 2022 AMPR

## Reporting on performance

**21** Volume I of the 2022 AMPR followed the corporate management board's guidance and presented a high-level performance overview, addressing in particular key issues like the EU's support to Ukraine, the RRF and sound financial management.

**22** It can take several years to deliver results from EU spending. Budgetary commitments are approved before making payments and results are often not readily measurable in the early years of programme implementation within a multiannual financial framework (MFF) period. Programmes implemented under the previous MFF can continue to deliver results in the current MFF. For this reason, the PPSs in Volume III of the AMPR included information on programmes from the previous 2014-2020 MFF period.

**23** In 2022, the 2021-2027 MFF was still in its early stages of implementation. Moreover, the reporting of shared management programmes and their corresponding indicators requires data from the members states, which takes some time due to the nature of the programmes. This means that the 2022 AMPR and the PPSs related to shared management contained performance data up to 31 December 2021, while the programmes under direct and indirect management can include data up to 31 December 2022.

**24** Volume I of the 2021 AMPR had a paragraph, including a graphical presentation, addressing the evolution of programmes under the previous MFF period (see also paragraph 27). This was drawn from indicator data at programme level. The EU budget and its spending programmes form a complex ecosystem and an overall presentation on implementation was useful. Volume I of the 2022 AMPR did not present such consolidated information although the information was available at programme level.

## Consistency of the AMPR with our reports

**25** We published 28 special reports in 2022. These addressed many of the challenges that the EU faces across its different spending areas and policies. Our annual report

for 2022 mapped these messages into five strategic areas: COVID-19; competitiveness; resilience and EU values; climate change, environment and natural resources; and fiscal policies and public finances. The nature of the audit process means that our audits mostly examined spending prior to 2022 and therefore topics addressed by the 2022 AMPR (e.g. Russia's war of aggression against Ukraine, the RRF) largely fell outside the specific scope of our 2022 special reports. However, these special reports and Volume I of the Commission's AMPR addressed common themes, including climate change, digitalisation, and the response to COVID-19.

**26** Volume I of the AMPR gives an overview of support from the EU budget and NextGenerationEU to climate mainstreaming. The total figure of €119.4 billion reported by the Commission includes €17.6 billion from the common agricultural policy (CAP). Our [2021 annual report on performance](#), applying the same methodology to track climate related expenditure for the CAP we used in our [special report 09/2022](#) on climate spending, calculated that the amount reported by the Commission in 2021 (€17.2 billion) was overstated by €8.9 billion. As the tracking methodology for the new CAP will apply after the transition period from 2023, the Commission used the same methodology in 2022 as for 2021. Therefore, our comment concerning the overstatement is also relevant for the 2022 AMPR.

**27** In our [2019 annual report on performance](#), we recommended that the Commission should continue to report on the performance of EU spending programmes for at least as long as substantial payments related to a given MFF period were being made. The Commission accepted this recommendation. We reported on the follow-up of this recommendation in our [2022 annual report](#), and considered that this recommendation had been fully implemented.

**28** In Volume I of the AMPR, the Commission noted that effective tools were in place to ensure accountability, transparency and sound financial management of the EU budget. Based on the results of the controls and audits, it reported that the risk at payment was estimated at 1.9 %. This was similar to 2021 and close to the materiality threshold of 2 %. It also reported an estimated risk at closure at 0.9 %, representing the remaining level of error at the end of the programme cycle when all controls and corrections have been implemented.

**29** We report on issues related to the Commission's internal control and sound financial management in our annual report. In chapter 1 of our [annual report for 2022](#) (see paragraphs 1.33-1.35), we noted that the Commission's risk at payment for 2022

of 1.9 % is significantly below our estimated level of error of 4.2 %. The ECA calculates this error rate in line with its [EU Treaty mandate](#) to provide a statement of assurance.

**30** In its replies to chapter 1 of our annual report, the Commission stated that it was confident that the information regarding the risk at payment (1.9 % in 2022) presented in the AMPR was representative of the level of error at the time of payment and noted that it did not share the same conclusions as the ECA on specific expenditure areas.

**31** One of the main reasons in the difference between percentages reported by the ECA and the Commission is due to MFF heading 2 ‘Cohesion, Resilience and Values’, which we addressed in chapter 6 of our annual report. Our error rate considers conditions for payment set out in the FR, the Common Provisions Regulation (CPR), and the Regulation on the protection of the EU’s financial interests. We reported that although the Commission concurred with our overall opinion that there was a material level of error in cohesion spending, the Commission’s error estimates were significantly lower than ours. The ECA’s estimated level of error for MFF heading 2 was 6.4 % while the Commission’s maximum estimate was 2.6 % (see paragraphs 6.64-6.67).

**32** In its replies to chapters 1 and 6 of our annual report, the Commission attributed this difference to the fact that the ECA’s estimated error rate was related to any breach of applicable rules. The Commission did not necessarily consider the associated expenditure ineligible, and noted that for programme authorities and the Commission to impose financial corrections, an error must be an irregularity within the sense of Article 2(36) of the CPR<sup>8</sup>.

**33** Volume I of the AMPR follows the strategic guidance of the corporate management board also when summarising the achievements of budgetary management. It refers to the sharp rise in interest rates and inflation exerting significant pressure on the EU budget, and the limited budgetary flexibilities in the current MFF. Chapter 2 of our annual report, dealing with budgetary and financial management, referred to these challenges. We also noted that outstanding commitments reached a record level of over €450 billion. Volume I of the AMPR does not refer to this, but the Commission reports on the level of outstanding commitments in its long-term forecasts of future inflows and outflows of the EU budget (see paragraph 01). Annex 4 of Volume III of the AMPR also gives information on commitments and payments at programme level, but not on outstanding

---

<sup>8</sup> This is a reference to the CPR applicable for the 2014-2020 programming period.

commitments. In its replies to chapter 2, the Commission stated that it regularly informs the Council and the European Parliament of the forecast needs and that it would continue proposing levels of payment appropriations that adequately meet payment needs during the annual budgetary procedures.

**34** The AMPR presents the RRF in different sections. Volume I covers its overall deployment and internal control management, while Annex 3 in Volume II is specifically dedicated to the RRF. The Commission noted in Volume I of the AMPR that its control results confirm the satisfactory fulfilment of all the milestones and targets for payments made in 2022.

**35** In chapter 11 of our annual report, we reported that 15 of the 281 milestones and targets for the RRF we audited were affected by regularity issues. We estimated the minimum financial impact of these findings to be close to our materiality threshold. The chapter noted that in Annex 6 of the 2022 AMPR, the Internal Audit Service raised an emphasis of matter on the RRF implementation referring to the need to further reinforce measures to protect the EU budget. We also noted that our findings and conclusions were not in line with the declaration of assurance provided by the Directorate-General for Economic and Financial Affairs' (DG ECFIN) authorising officer.

**36** In its replies to chapter 11, the Commission considered that its original assessment of 'satisfactory fulfilment' was correct. It also noted that the ECA's conclusions that some milestones and targets were not satisfactorily fulfilled were principally based on differences in interpretation of the legal requirements, or differences in the qualitative judgement.

### **Accuracy of the quantitative assertions related to performance in Volume I of the 2022 AMPR**

**37** We reviewed the main quantitative assertions made by the Commission in Volume I of its 2022 AMPR. This covered 70 % of the amounts higher than €1 billion for which we requested and obtained supporting information and explanations from the Commission. In addition to this, we looked at whether selected amounts from Volume I were consistent with amounts reported in the AMPR annexes, in the AARs and in the EU's financial statements. This review did not note inconsistencies.

## Concluding remarks

**38** The legal deadline for the Commission to make available the AMPR by end of June of the following year limits what we can address comprehensively in time for the annual discharge procedure. This review therefore focuses on Volume I of the 2022 AMPR (paragraphs [01](#) and [10](#)).

**39** This volume of the AMPR followed the strategic guidance of the Commission's corporate management board and presented the key facts and achievements in relation to budgetary management for 2022. In our previous reporting, we noted that the Commission had good procedures for preparing the AMPR, but there was still room for improvement with regards to the quality of performance data collected and presentation of consolidated performance information (paragraphs [11-24](#)).

**40** Our review noted that, based on our previous work, we would consider the Commission's calculation of the contribution of the CAP to climate expenditure to be overstated. An updated tracking methodology for the new CAP will apply from 2023 (paragraph [26](#)).

**41** Concerning the content of our annual report, the AMPR reflected the fact that the Commission does not share the same conclusions as the ECA with regard to specific areas of expenditure. The Commission reported a risk at payment for the 2022 budget of 1.9 %, which is significantly lower than the error rate of 4.2 % we present in our annual report. The ECA calculates this error rate in line with its [EU Treaty mandate](#) to provide a statement of assurance (paragraphs [28-32](#)).

**42** For the RRF, our annual report concluded that 15 of the 281 milestones and targets we audited were affected by regularity issues. The Commission did not share our interpretation in these cases. Volume I of the AMPR reported that all milestones and targets for payments made in 2022 had been satisfactorily fulfilled (paragraphs [35-36](#)).

**43** In addition, we drew attention in our annual report to the record level of outstanding commitments in 2022. This was not referred to in Volume I of the AMPR, but the Commission addressed the level of outstanding commitments in its long-term forecasts of future inflows and outflows of the EU budget (paragraph [33](#)).

**44** Our review of the main quantitative assertions made by the Commission in Volume I of the AMPR did not identify other inconsistencies (paragraph **37**).

This review was adopted by Chamber V, headed by Mr Jan Gregor, Member of the Court of Auditors, in Luxembourg at its meeting of 24 October 2023.

*For the Court of Auditors*

Tony Murphy  
*President*

## Annexes

### Annex I – Roles of different participants in producing the Commission’s main performance reporting documents

Report	Central services (DG BUDG/SEC-GEN)	DGs	College
AMPR	<ul style="list-style-type: none"> <li>○ draft the report</li> <li>○ follow strategic orientations from the corporate management board</li> <li>○ consult responsible DGs</li> </ul>	<ul style="list-style-type: none"> <li>○ indicate main issues/messages to be included in the AMPR in their programme statements and AAR</li> <li>○ provide feedback on drafts</li> </ul>	<ul style="list-style-type: none"> <li>○ ensures consistency of political messages</li> <li>○ adopts the report</li> </ul>
PPSs	<ul style="list-style-type: none"> <li>○ issue templates/instructions/guidelines ('budget circular') and provide training</li> <li>○ review drafts and send feedback to responsible DGs</li> </ul>	<ul style="list-style-type: none"> <li>○ collect data for the indicators</li> <li>○ draft the programme statements</li> </ul>	<ul style="list-style-type: none"> <li>○ Adopts the report (as part of the draft budget proposal)</li> </ul>
AAR	<ul style="list-style-type: none"> <li>○ issue templates/instructions/guidelines</li> <li>○ review drafts and send feedback to responsible DGs</li> <li>○ organise peer reviews</li> </ul>	<ul style="list-style-type: none"> <li>○ draft report</li> <li>○ sign off report (Director-General)</li> </ul>	<ul style="list-style-type: none"> <li>○ decides on the follow-up</li> </ul>

## Annex II – Programme performance statements

The PPSs included in the technical annexes of Volume III present all EU spending programmes financed through the MFF in a concise and uniform way and their main elements are:

- what the programme is about (mission, objectives and structural set-up, link to the 2014-2020 MFF);
- the budget implementation and performance;
- the contribution to horizontal priorities like green, gender and digital;
- the performance assessment based on key performance indicators indicating baseline, target and actual value of the indicator, together with an assessment of whether progress is on track;
- the contribution to the sustainable development goals.

# Abbreviations

**AAR:** annual activity report

**AMPR:** annual management and performance report

**CAP:** common agricultural policy

**CPR:** Common Provisions Regulation

**DG BUDG:** Directorate-General for Budget

**DG ECFIN:** Directorate-General for Economic and Financial Affairs

**FR:** Financial Regulation

**MFF:** multiannual financial framework

**PPS:** programme performance statements

**RRF:** Recovery and Resilience Facility

**SEC-GEN:** Secretariat-General

## Glossary

**Annual activity report:** Report produced by each Commission directorate-general and EU institution or body, setting out how it has performed in relation to its objectives, and how it has used its financial and human resources.

**Annual management and performance report:** Report produced every year by the Commission on its management of the EU budget and the results achieved, summarising the information in the annual activity reports of its directorates-general and executive agencies.

**Annual report:** ECA annual audit report containing a statement of assurance on the reliability of the EU accounts and the regularity of underlying transactions, which the ECA is required to provide to the European Parliament and the Council in accordance with the Treaty on the Functioning of the European Union.

**Climate change:** Changes in the Earth's climate that result in new long-term weather patterns.

**Climate mainstreaming:** Incorporating climate-related considerations in all policies, instruments, programmes and funds.

**Commitment:** Amount earmarked in the budget to finance a specific item of expenditure, such as a contract or grant agreement. Outstanding commitments are the sum of commitments made but not yet translated into payments.

**Common agricultural policy:** The EU's single unified policy on agriculture, comprising subsidies and a range of other measures to guarantee food security, ensure a fair standard of living for the EU's farmers, promote rural development and protect the environment.

**Common Provisions Regulation:** Regulation setting out the rules that apply to all five of the European Structural and Investment Funds.

**Corporate management board:** Central management body of the Commission, providing coordination, oversight, advice and strategic direction on corporate issues, including resource allocation and risk management. It meets regularly, is chaired by the Secretary-General and brings together the directors-general responsible for budget, human resources and security, and the Director-General of the Legal Service. Senior members of the relevant Commissioners' cabinets participate as observers.

**Digitalisation:** Introducing digital technology and digitised information to processes and tasks.

**Direct management:** Management of an EU fund or programme by the Commission alone, as opposed to shared management or indirect management.

**Discharge:** Annual decision taken by the European Parliament giving the Commission final approval for the way a budget has been implemented.

**Error:** Result of an incorrect calculation or an irregularity arising from non-compliance with legal and contractual requirements.

**Error rate:** Statistical estimate of the error affecting a population, based on testing of a representative sample of transactions drawn from that population.

**Financial Regulation:** The rules governing how the EU budget is set and used, and the associated processes such as internal control, reporting, audit and discharge.

**Indicator:** Information used to measure or assess an aspect of performance. A key performance indicator measures performance against key objectives.

**Indirect management:** Method of implementing the EU budget whereby the Commission entrusts implementation tasks to other entities (such as non-EU countries and international organisations).

**Multiannual financial framework:** The EU's spending plan setting priorities (based on policy objectives) and ceilings, generally for 7 years. It provides the structure within which annual EU budgets are set, limiting spending for each category of expenditure.

**Programme:** The means by which specific EU policy objectives are delivered, generally through co-financed projects.

**Programme statement:** Justification for the operational appropriations requested by the Commission for each spending programme in the draft annual budget, based on implementation in previous years measured through indicators.

**Recovery and Resilience Facility:** The EU's financial support mechanism to mitigate the economic and social impact of the COVID-19 pandemic and stimulate recovery, and meet the challenges of a greener and more digital future.

**Regularity:** Extent to which a transaction or activity complies with the applicable rules and regulations and any contractual obligations.

**Shared management:** Method of spending the EU budget in which, in contrast to direct management, the Commission delegates to the member state while retaining ultimate responsibility.

**Sound financial management:** Management of resources in accordance with the principles of economy, efficiency and effectiveness.

**Special report:** Document setting out the findings of an ECA audit to determine whether an activity has adhered to the principles of sound financial management and achieved its objectives.

**Sustainable Development Goals:** The 17 goals set in the United Nations 2030 Agenda for Sustainable Development to stimulate action by all countries in areas of critical importance for humanity and the planet.

## ECA team

This review was adopted by Chamber V Financing and administering the Union, headed by ECA Member Jan Gregor. The task was led by ECA Member Mr Jorg Kristijan Petrovič, supported by Martin Puc, Head of Private Office and Mirko Iaconisi, Private Office Attaché; Colm Friel, Principal Manager; Mircea-Cristian Martinescu, Head of Task; Dana Šmíd Foltýnová, and Roland Schober, Auditors. Jesús Nieto Muñoz provided graphical support. Laura McMillan provided linguistic support.

# COPYRIGHT

© European Union, 2023

The reuse policy of the European Court of Auditors (ECA) is set out in [ECA Decision No 6-2019](#) on the open data policy and the reuse of documents.

Unless otherwise indicated (e.g. in individual copyright notices), ECA content owned by the EU is licensed under the [Creative Commons Attribution 4.0 International \(CC BY 4.0\) licence](#). As a general rule, therefore, reuse is authorised provided appropriate credit is given and any changes are indicated. Those reusing ECA content must not distort the original meaning or message. The ECA shall not be liable for any consequences of reuse.

Additional permission must be obtained if specific content depicts identifiable private individuals, e.g. in pictures of ECA staff, or includes third-party works.

Where such permission is obtained, it shall cancel and replace the above-mentioned general permission and shall clearly state any restrictions on use.

To use or reproduce content that is not owned by the EU, it may be necessary to seek permission directly from the copyright holders.

Software or documents covered by industrial property rights, such as patents, trademarks, registered designs, logos and names, are excluded from the ECA's reuse policy.

The European Union's family of institutional websites, within the europa.eu domain, provides links to third-party sites. Since the ECA has no control over these, you are encouraged to review their privacy and copyright policies.

## **Use of the ECA logo**

The ECA logo must not be used without the ECA's prior consent.

PDF	ISBN 978-92-849-1260-5	ISSN 2811-8197	doi: 10.2865/688580	QJ-04-23-003-EN-N
-----	------------------------	----------------	---------------------	-------------------

The annual management and performance report (AMPR) is the Commission's high-level performance report on the EU budget, and part of the Commission's annual financial reporting package. The legal deadlines involved limit what we can address comprehensively in time for the annual discharge procedure and consequently this review focuses on Volume I of the 2022 AMPR. Our review notes that overall the Commission had good procedures for its preparation. We also highlight that the AMPR reflects the fact that the Commission does not share the same conclusion as we do on specific expenditure areas, and that there was scope to improve the quality of performance data.

**EUROPEAN COURT OF AUDITORS**  
12, rue Alcide De Gasperi  
1615 Luxembourg  
LUXEMBOURG

Tel. +352 4398-1

Enquiries: [eca.europa.eu/en/contact](https://eca.europa.eu/en/contact)

Website: [eca.europa.eu](https://eca.europa.eu)

Twitter: @EUAuditors



EUROPEAN  
COURT  
OF AUDITORS